

Tesla patent talk: A battery-swapping system

September 19 2017, by Nancy Owano

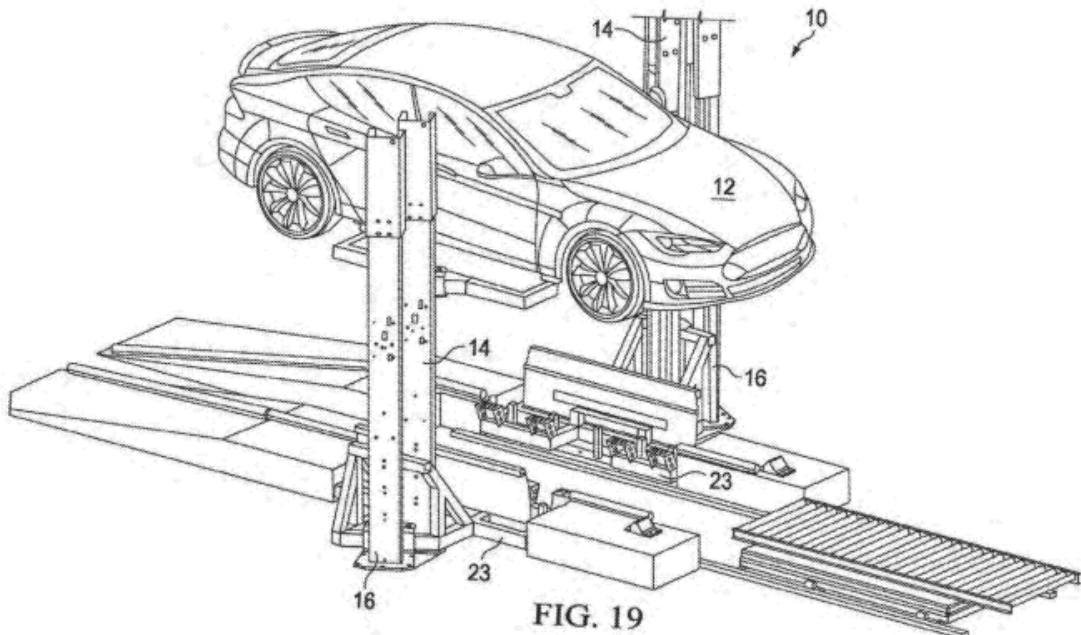

Patent Application Publication Sep. 14, 2017 Sheet 19 of 47 US 2017/0259675 A1

Credit: US Patent 20170259675

(Tech Xplore)—Tesla has filed a patent with the US Patent and Trademark Office, titled "Battery Swapping System and Techniques."

The [patent](#) describes a mobile [battery](#)-swapping rig.

Stories about the patent were posted in *TechCrunch* and a number of other sites. They have been talking about what was filed and what it could mean in the bigger scheme of all-things-Tesla.

Business Insider said the patent application "shows how the machine could elevate a [vehicle](#) and then replace its [battery pack](#) with a new one."

CleanTechnica described the technology as a "quick-swap Electric Energy Storage System (EESS)." It said figure details included a "2 pillar vehicle lift system" and battery lift *Gas2* said the patent discussed a system raising a vehicle in the air "with one set of hydraulic lifts while another inboard lift would drop the battery pack and replace it with a fully [charged](#) unit."

The machine proposed could make it quick to replace a battery in an electric vehicle. Matt Burns, managing editor, *TechCrunch*, explained a scenario for the system, as described in the patent, where the system "could be installed in a service station or integrated into a mobile rig. A Model S or X would either drive onto ramps or a lift where technicians would then assist the machine in swapping the [packs](#)."

The patent discussion suggested either the EESS operating autonomously, or operated by technicians.

The patent document discussed both systems and techniques for swapping an EESS. "In some implementations, a system can be used to exchange the battery pack of a Model S or Model X vehicle from Tesla Motors, Inc., for another (e.g., fully charged) battery pack. For example, this can provide a more rapid way of replenishing the electric energy for the electric vehicle and can enable [electric vehicles](#) to travel essentially nonstop on long road trips."

Also from the patent discussion: "In some implementations, the battery swap system is configured for use by one or more technicians, who will monitor certain aspects of the system's operation and make necessary inputs when appropriate. For example, the battery-swapping system can be installed at a remote location (e.g., along a highway between two cities) and one or more technicians can be stationed at the location for operating the system."

Brett Williams in *Mashable*: "The system described in the filing, which was first spotted by *Electrek*, would make it possible for technicians to [swap](#) out Tesla vehicle battery packs in less than 15 minutes—making it feasible for Tesla owners to use a battery exchange rather than constantly having to charge up."

"Tesla writes in the patent that at least one technician could monitor the lift," said *Business Insider*, "which could be installed in remote locations, such as a highway between [cities](#)."

Why is the patent drawing interest? That is not hard to figure out, since there is general range anxiety and concern over just how convenient or inconvenient electric cars might turn out to be vis a vis charging points.

"[One](#) of the biggest drawbacks for electric car drivers is the time it takes to charge their vehicles," said Rob Stumpf, *The Drive*.

A battery swap solution could come in handy, as Tesla continues its effort to play its part in the transition to electric mobility.

A number of reports linked this patent topic to Tesla's entry into the truck space some time in the future.

The system being used for trucks could make sense as a truck driver would especially be mindful of cutting down on charging times—and

getting back on the road quickly.

Yoni Heisler, *BGR*: "Elon Musk has been pretty blunt about Tesla's plans to further expand its [vehicular](#) lineup." When might Tesla unveil a pickup truck? Heisler said, "Musk this past April put a two year timeline on the project." Heisler added that "if Musk's initial projection pans out, we should see a Tesla pickup truck event by April of 2019 at the absolute latest. Suffice it to say, it's certainly on Tesla's radar."

More information: Battery Swapping System And Techniques, United States Patent Application, [20170259675](#).

Abstract

A system for exchanging an electrical energy storage system (EESS) of an electric vehicle includes. An EESS station is configured to position an electric vehicle in x and y directions. A vehicle lift raises the electric vehicle to a predetermined height. An EESS lift supports and lowers the EESS and replaces the EESS with a differing EESS. The vehicle lift may be an inboard lift and the EESS lift may be an outboard lift. The system may also include one or more rollers configured to guide the electric vehicle. The system may include a horizontal door having at least one tube positioned thereon for guiding the electric vehicle and/or at least one vehicle chock for positioning the electric vehicle in at least one of the x and y directions. The vehicle lift may include lifting arms to engage jack pads of the electric vehicle.

© 2017 Tech Xplore

Citation: Tesla patent talk: A battery-swapping system (2017, September 19) retrieved 8 June 2023 from <https://techxplore.com/news/2017-09-tesla-patent-battery-swapping.html>

This document is subject to copyright. Apart from any fair dealing for the purpose of private

study or research, no part may be reproduced without the written permission. The content is provided for information purposes only.