

# Contact lens: You blink and you zoom in

July 30 2019, by Nancy Cohen

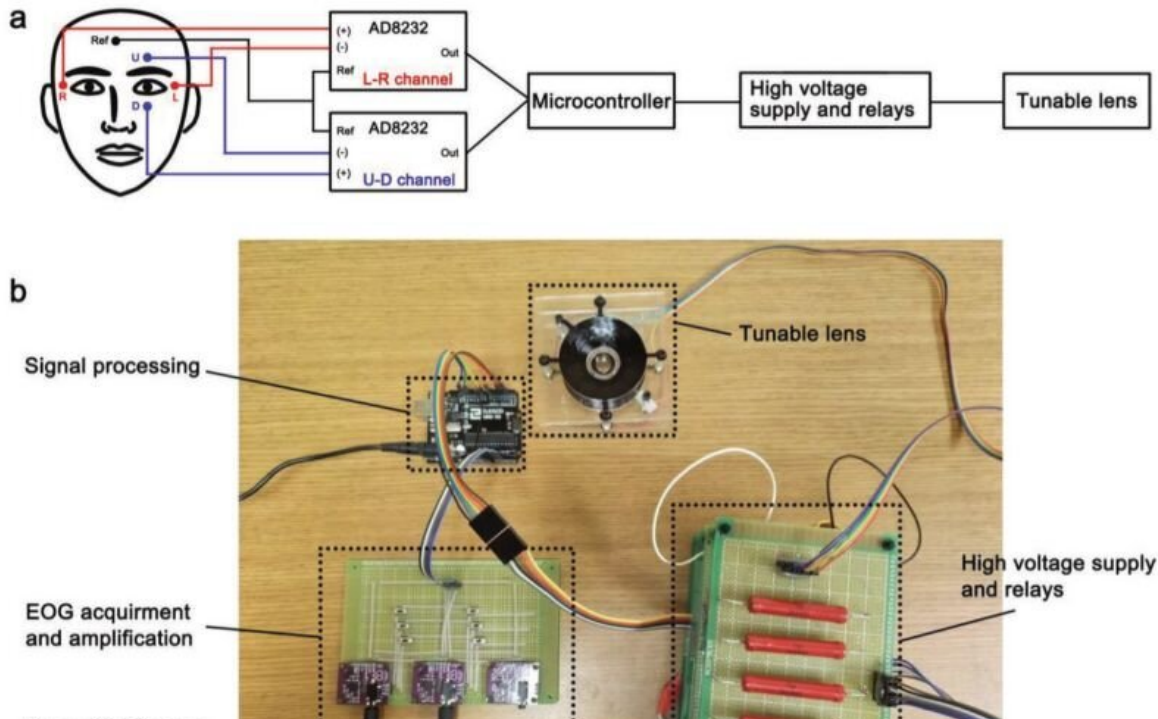

Schematic and photograph of the system setup. Credit: *Advanced Functional Materials* (2019). DOI: 10.1002/adfm.201903762

Researchers are in the news this week because of their soft biomimetic lens. Blink twice and you get yourself a closer look at things. Activated soft elastomer works to increase focal length.

Their paper is titled "A Biomimetic Soft Lens Controlled by

Electrooculographic Signal, Soft Robotics, in *Advanced Functional Materials* by Yang Wang, Sheng Xu, Liwu Liu, Jinrong Li .

They described their work in having developed the robotic lens.

The way *Popular Mechanics* sees it, these lenses are actually [soft](#) robots. Daisy Hernandez said Monday that the contact lenses use the electrooculographic signal naturally produced by our eyes to perform tasks of zooming in and out.

[Electrooculography](#) is a technique for recording eye movements. In discussing this paper, *E&T* noted that "Electrooculography is commonly used to assess optical function and inform diagnoses, but has also been employed as a computer input for the Neural Impulse Actuator brain-computer interface, and for animating details of film characters based on real performances."

The human eyeball is electric, said Leah Crane in *New Scientist*, with "a steady electrical potential between its front and back, even when your eyes are closed or in total darkness. When you move your eyes to look around or blink, the motion of the electrical potential can be [measured](#)."

*E&T* explained "When the contact lens detects the signals associated with certain movements, its [focal length](#) shifts through the actuation of different regions of thin elastomer films in a process inspired by the biological mechanisms in most [mammal](#) eyes (including human eyes). This allows the wearer to zoom in and out using simple eye movements."

Fabienne Lang in *Interesting Engineering* said the researchers measured electrooculographic [signals](#) created by eye movements—"look up, down, left, right, blink, double blink -" and then made a soft biomimetic lens responding to those movements.

The authors have worked up an interface between humans and a biomimetic soft lens. This enables control of the lens by electrooculographic signals. They explained how "[Triggered](#) by a double blink, the lens can be switched from a near vision mode to a distance vision mode due to the focal length change." Within each mode, the lens can move following the direction of the eye motions.

How it works: electrodes are spread across the contacts to act as muscles. These are made up of layers of electroactive polymer designed to expand when they receive an electrical signal from the eye, said Hernandez.

What inspired them to follow this line of research? Their title refers to a biomimetic soft lens. (Biomimetics, said *nature.com*, is "an interdisciplinary field in which principles from engineering, chemistry and biology are applied to the synthesis of materials, synthetic systems or machines that have [functions](#) that mimic biological processes.")

The authors talked about inspiration from the human eye. Inspired by the motion and the tuning of focal length of the eye-ball of human beings and mammals, they said, they designed a novel soft and tunable lens using DE (dielectric elastomer) films.

The soft lens was mainly composed of electroactive polymer films. The change of the focal length and motion of the soft lens resembled those of [human eyes](#), achieved by the electrical potential-induced actuation of DE films.

*Interesting Engineering* commented that the researchers had a purpose beyond entertaining the curious. "Aside from how nifty it is," the scientists hoped this will assist in visual prostheses, adjustable glasses, and remotely operated robotics.

Moving forward, "The system developed in the current study has the

potential to be used in visual prostheses, adjustable glasses, and remotely operated robotics in the future," the authors said.

Andrew Liszewski in *Gizmodo* pointed out, however, that there was "a lot of refinement needed before glasses [wearers](#) would even consider switching to a contact lens that offered such functionality. Few of us are willing to walk around with electrodes stuck all over our faces, so considerable refinement would be needed to attempt to integrate all of the requisite electronics into the lens themselves. That will require some major breakthroughs from companies with lots of funding to spend on R&D, however."

This would not be the first time that research has been carried out on [contact lenses](#) used for control. Previously, said *E&T*, scientists at the Swiss Federal Institute of Technology in Lausanne presented a contact lens that allowed the [wearer](#) to zoom in and out when they winked. There was a tiny set of aluminium mirrors arranged in a ring around the center of the [lens](#). Special glasses were required in this setup to switch between standard and zoomed-in views.

"To toggle between the magnified and normal views, the lenses must be worn with a pair of electronic glasses. A wink with one eye makes the glasses switch to a polarised filter that directs light to the telescopic part of the lenses. Winking with the other eye switches the setting back to let light pass through normally," said *New Scientist* in 2015.

**More information:** Jinrong Li et al. A Biomimetic Soft Lens Controlled by Electrooculographic Signal, *Advanced Functional Materials* (2019). [DOI: 10.1002/adfm.201903762](https://doi.org/10.1002/adfm.201903762)

Citation: Contact lens: You blink and you zoom in (2019, July 30) retrieved 12 August 2024 from <https://techxplore.com/news/2019-07-contact-lens.html>

This document is subject to copyright. Apart from any fair dealing for the purpose of private study or research, no part may be reproduced without the written permission. The content is provided for information purposes only.