

LiftTiles: Actuator-based building blocks for shape-changing interfaces

January 28 2020, by Ingrid Fadelli



Credit: Suzuki et al.

Large-scale interfaces that change shape could be used to create interactive displays or environments that can be adapted to meet the needs human users. Despite their potential, creating these systems has so far proved challenging, as they can be expensive to build and require a space big enough to allow different configurations.

Researchers at the University of Colorado Boulder's ATLAS Institute, Keio University and the University of Tokyo have recently created a set of modular building blocks, dubbed LiftTiles, that can be used to create room-scale shape-changing interfaces. The design of these unique building blocks, presented in [a paper pre-published on arXiv](#), is inspired by the mechanism behind party horns.

"We wanted to create changeable architectural (room-size) experiences—walls, floors and furniture that can be arranged and rearranged under [computer control](#)," Ryo Suzuki, the Ph.D. student at the ATLAS Institute who came up with the design, told TechXplore.

The idea of using pneumatics and inflatable actuators to create room-size architectural experiences dates back to the 1970s, and more specifically, to a project dubbed the [INFLATOCOOKBOOK](#), by avant-garde architecture group Ant Farm. More recently, several other designers and architects started using inflatable materials to build large-scale 3-D displays. A few noteworthy examples are [Asif Khan's 3-D billboard](#), presented at the Sochi Olympics in 2014, and [an installation](#) created by the Scandinavian Design Group in Norway, consisting of an interactive ceiling.

Researchers specialized in the development of human-computer interaction techniques have also been investigating the use of pneumatics and other inflatable materials to create shape-changing displays. However, most of the resulting interfaces have been relatively small in size or rely on a monolithic design (i.e., formed by a single large block rather than several small blocks).

The interface created by Suzuki and his colleagues uses actuators as large, modular building blocks. In contrast with some of the previously proposed interfaces, their design allows users to build room-size and shape-changing displays easily, customizing them based on their needs.

"Full-size 3-D displays are expensive and time-consuming to construct," Suzuki said. "The main objective of the LiftTiles project is to enable designers and developers to quickly and easily build a working prototype of a room-size shape-changing [interface](#) so that they (and we) can experience it before embarking on the costly and time-intensive process of constructing a robust and finished product."

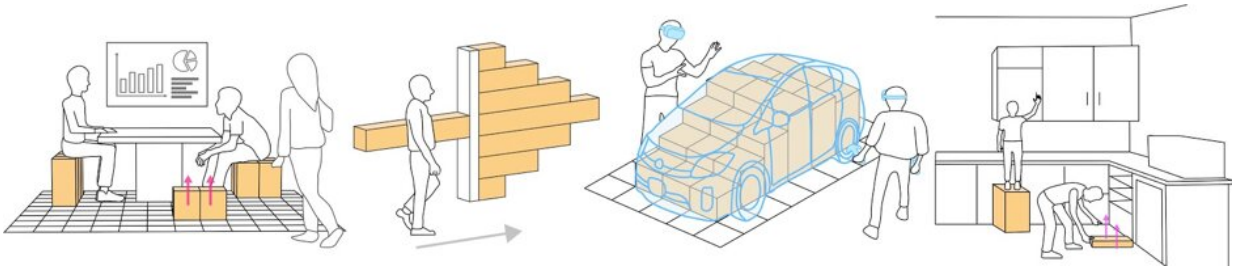

Credit: Suzuki et al.

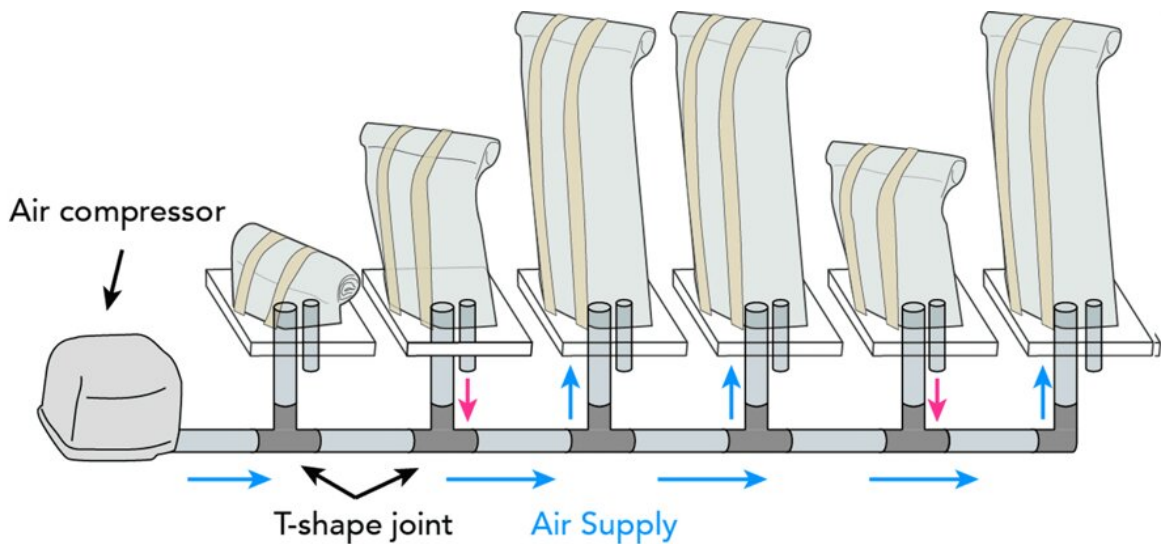

Credit: Suzuki et al.

The LiftTiles created by Suzuki and his colleagues are essentially 30cm square tiles that can be raised and lowered from 15cm to 150cm using a computer. Each tile is raised individually by inflating a flexible tube that is rolled on a spring driven reel, resembling the movement of a party horn as it extends. When it is deflated, the same tube retracts and rolls

up again, lowering the tile.

LiftTiles have several advantages compared to other building blocks used to create large-scale shape-shifting interfaces. Firstly, the tiles weigh 10kg each and are strong enough to support another 10kg. They are also compact and can be compressed down to 15cm.

Assembling a single tile, which comprises the tile itself and the flexible tube, costs \$8. LiftTiles could thus be an inexpensive and effective solution for building working prototypes of room-size shape-changing interfaces.

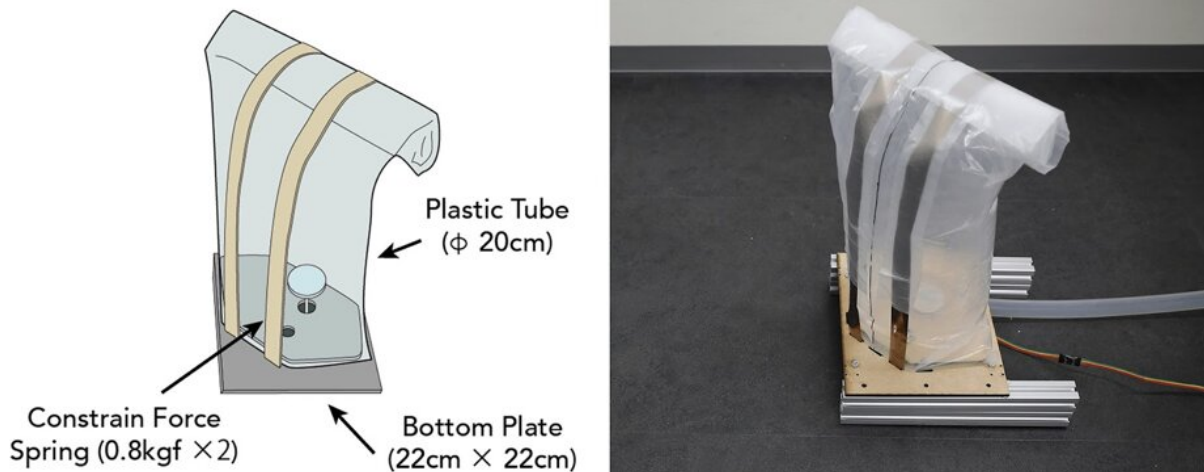

Credit: Suzuki et al.

"We developed a low-cost modular design for reel-wound pneumatic actuators that are rather inexpensive and powerful enough to lift 10 kg," Suzuki explained. "The combination of its characteristics make LiftTiles well-suited for prototyping room-scale shape transformations, as their modular and reconfigurable design enables researchers and designers to quickly construct different geometries and to investigate applications."

The actuator-based building blocks could soon be used by designers worldwide to build mock-up displays, ultimately producing a variety of environments. For instance, users could create shape-changing floors for adaptive furniture, shape-changing walls for dynamic partition and environmental haptic interfaces for immersive VR experiences.

"In our studies, we would like to find ways to make LiftTiles faster," Suzuki said. "Fully extending a LiftTile takes 16 seconds and fully retracting it takes 4 seconds, too slow to support, for example, a room-size VR game. We also plan to conduct a workshop with researchers and designers (e.g., interior designers and architects) to explore and prototype applications of LiftTiles."



Credit: Suzuki et al.

In the future, Suzuki and his colleagues plan to provide the tiles with acoustic, capacitive and pressure-sensing capabilities, enhancing their interactions with the surrounding environment. They also plan to give them a more dynamic appearance, for instance, by installing LED lights on their surface.

"Currently, we control each LiftTile through a central microcontroller, connected with wires, and this limits the arrangements of LiftTiles on

the floor," Suzuki added. "Replacing the wires with Wi-Fi connections would allow us to overcome this limitation."

More information: LiftTiles: constructive building blocks for prototyping room-scale shape-changing interfaces. arXiv:2001.02382 [cs.HC]. arxiv.org/abs/2001.02382

ryosuzuki.org/lift-tiles/

© 2020 Science X Network

Citation: LiftTiles: Actuator-based building blocks for shape-changing interfaces (2020, January 28) retrieved 10 December 2023 from <https://techxplore.com/news/2020-01-lifftiles-actuator-based-blocks-shape-changing-interfaces.html>

This document is subject to copyright. Apart from any fair dealing for the purpose of private study or research, no part may be reproduced without the written permission. The content is provided for information purposes only.