

Interference cancellation with high precision, high speed and low computational complexity

May 1 2020

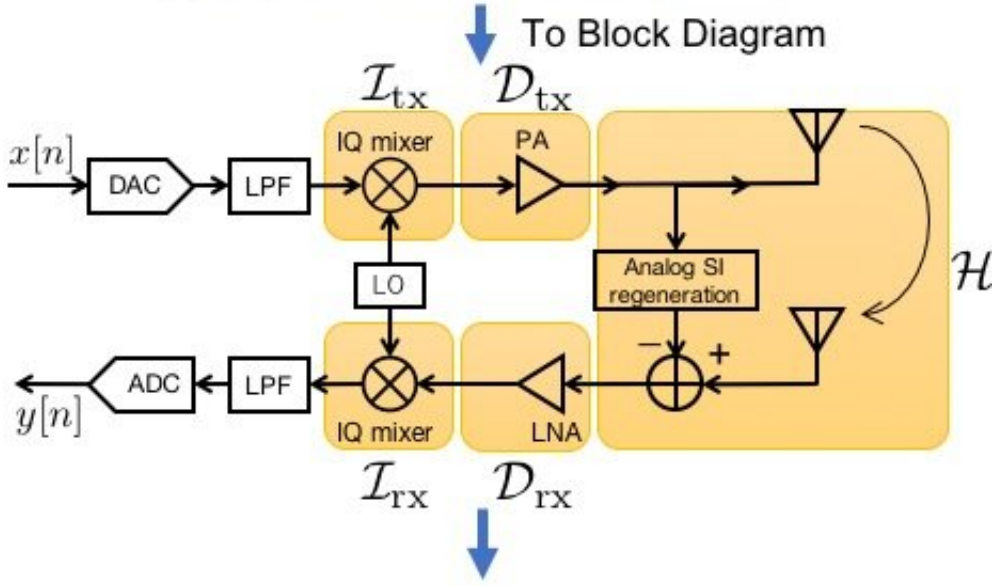
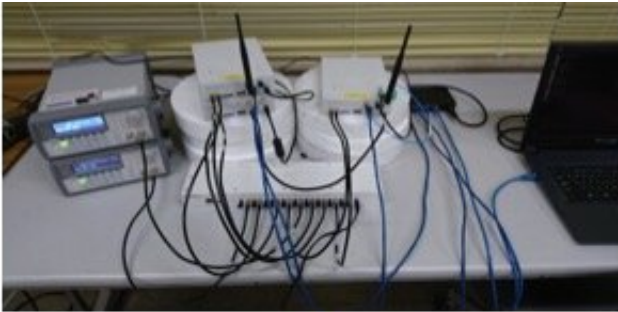

Mathematical Model with Five Operators

$$y[n] = \mathcal{I}_{rx} \mathcal{D}_{rx} \mathcal{H} \mathcal{D}_{tx} \mathcal{I}_{tx} x[n]$$

In-band full-duplex transceiver (top), circuit block model of transceiver (middle), mathematical model using five operators (bottom). Credit: Toyohashi University Of Technology.

The research team of Assistant Professor Miyaji of the Department of Electrical and Electronic Information Engineering at Toyohashi University of Technology has developed a self-interference cancellation filter that is indispensable for the realization of in-band full duplex using the same frequency to transmit and receive simultaneously in wireless communications. This self-interference cancellation filter can estimate the distortion caused by radio and the distortion of the radio channel with high accuracy and cancel self-interference. In addition, it can quickly reach the solution of the filter with low computational complexity. It is expected to be applied to next-generation wireless communication technology.

In [wireless communications](#), simultaneous transmission and reception using the same frequency (in-band full duplex) is a very difficult task. Even in the latest wireless communication standard 5G, this in-band full duplex has not been realized. Currently, it is necessary to divide the time when transmitting and receiving at the same frequency, or to divide the frequency when transmitting and receiving at the same time. It is necessary to separate one of them (time or frequency) because the strength of the [radio](#) wave that it emits is up to several hundred million times greater than the strength of the radio wave to receive (self-interference).

The filters considering multiple distortions that have been developed so far remove the self-interference with high precision, but also require high computational complexity and take a long time to obtain the solution of the filter. Therefore, the research team of Assistant Professor Miyaji worked on the development of a self-interference cancellation filter that simultaneously satisfies the conditions of high precision, high speed, and low computational complexity.

The first author, Kazuki Komatsu, in the [doctoral program](#) (JSPS Research Fellow), explains, "Compared to [base stations](#), low-cost radios

such as smartphones have complex distortions, and self-interference cancellation in such devices is a very [difficult problem](#). To solve a complex problem, it is important to boil the problem down to its essence and break it down into multiple smaller problems. We have decomposed the problem of self-interference cancellation due to the complex [distortion](#) of radio equipment into five small problems and expressed each using mathematical operators. As a result, it was clarified that the solution method of each small problem and the solution method of the big problem which connected them could be derived using five operators and their inverse operators. By applying the derived solution to a filter, we were able to cancel self-interference with higher precision, higher speed, and lower computational complexity than before. The developed filter increases the feasibility of in-band full-duplex communications in small and inexpensive radios such as smartphones."

The research team is planning theoretical performance analysis and field evaluation of the developed self-interference [cancellation](#) filter. They also believe that by using the filter, it can be applied to wireless networks that cooperate with small mobile objects such as drones. Since it is necessary to recreate the filters periodically according to changes in the radio environment due to movement, we can expect contributions from this technology, which has the features of high precision, high speed, and low calculation complexity.

More information: Kazuki Komatsu et al, Iterative Nonlinear Self-Interference Cancellation for In-Band Full-Duplex Wireless Communications Under Mixer Imbalance and Amplifier Nonlinearity, *IEEE Transactions on Wireless Communications* (2020). [DOI: 10.1109/TWC.2020.2983407](#)

Provided by Toyohashi University of Technology

Citation: Interference cancellation with high precision, high speed and low computational complexity (2020, May 1) retrieved 21 April 2024 from <https://techxplore.com/news/2020-05-cancellation-high-precision-complexity.html>

This document is subject to copyright. Apart from any fair dealing for the purpose of private study or research, no part may be reproduced without the written permission. The content is provided for information purposes only.