

Researchers develop a compact 28 GHz transceiver supporting dual-polarized MIMO

June 17 2020

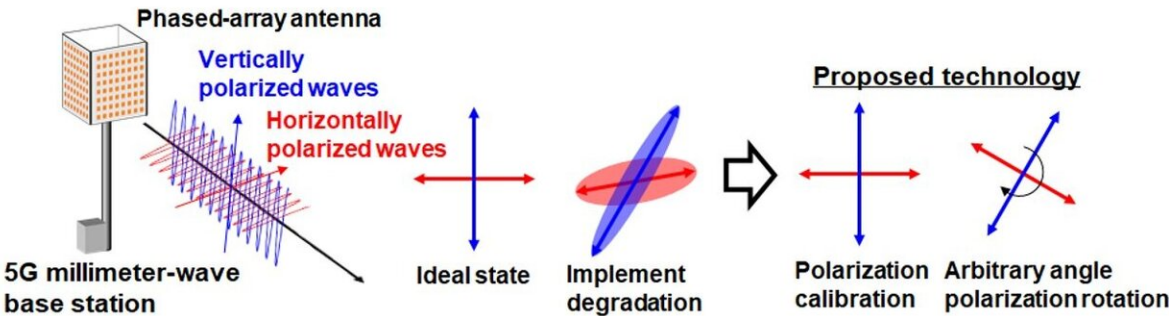

An illustration of leakage cancellation between polarization signals and arbitrary angle polarization rotation. Credit: 2020 Symposia on VLSI Technology and Circuits

Researchers at Tokyo Institute of Technology (Tokyo Tech) and NEC Corporation have jointly developed a 28-GHz phased-array transceiver supporting dual-polarized MIMO for 5G radio units. Advances in 5G will benefit an array of industries ranging from healthcare, manufacturing and transportation to education and entertainment that require high bandwidth and high-quality connectivity.

As countries launch or prepare for 5G services, researchers are continuing to step up efforts to facilitate deployment of 5G infrastructure. Dual-polarized phased-array transceivers are an attractive

class of antenna systems that can transmit data simultaneously through horizontal and vertical-polarized waves. Numerous studies have shown that dual-polarized MIMO can improve the data rate and spectrum efficiency in 5G radio units. However, one problem encountered with these systems is cross-polarization leakage, which results in degradation of signal quality especially in the millimeter wave band.

Now, Kenichi Okada's Lab at Tokyo Tech's Department of Electrical and Electronic Engineering and NEC corporation in Japan have developed a transceiver capable of canceling cross-polarization interference using a built-in so-called horizontal and vertical (H/V) canceller. Tests have shown that the error vector magnitude in 256QAM can be improved from 7.6% to a more desirable, lower figure of 3.3% using this new leakage cancelation technique. "The cancelation signals are generated for horizontal and vertical polarization at the transmission side so that it can cancel the cross-polarization leakage caused by all through the transmitter/receiver chip, package, printed circuit board and antenna," the researchers say.

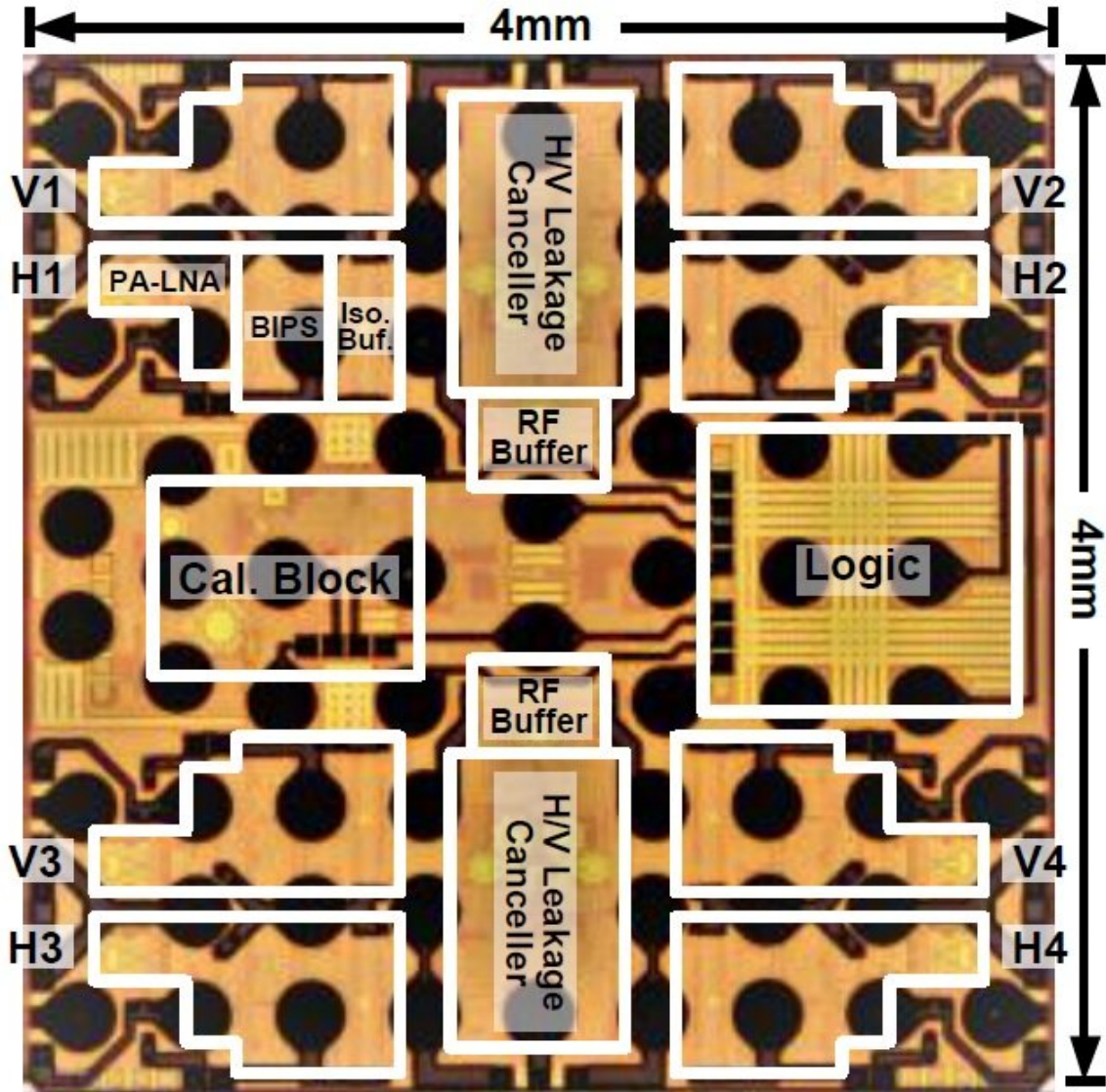

Researchers at Tokyo Institute of Technology and NEC Corporation have jointly developed a 28 GHz phased-array transceiver supporting dual-polarized MIMO for fifth-generation mobile communications system (5G) radio units. Advances in 5G will benefit an array of industries ranging from healthcare, manufacturing and transportation to education and entertainment that require high bandwidth and high-quality connectivity. Credit: 2020 Symposia on VLSI Technology and Circuits

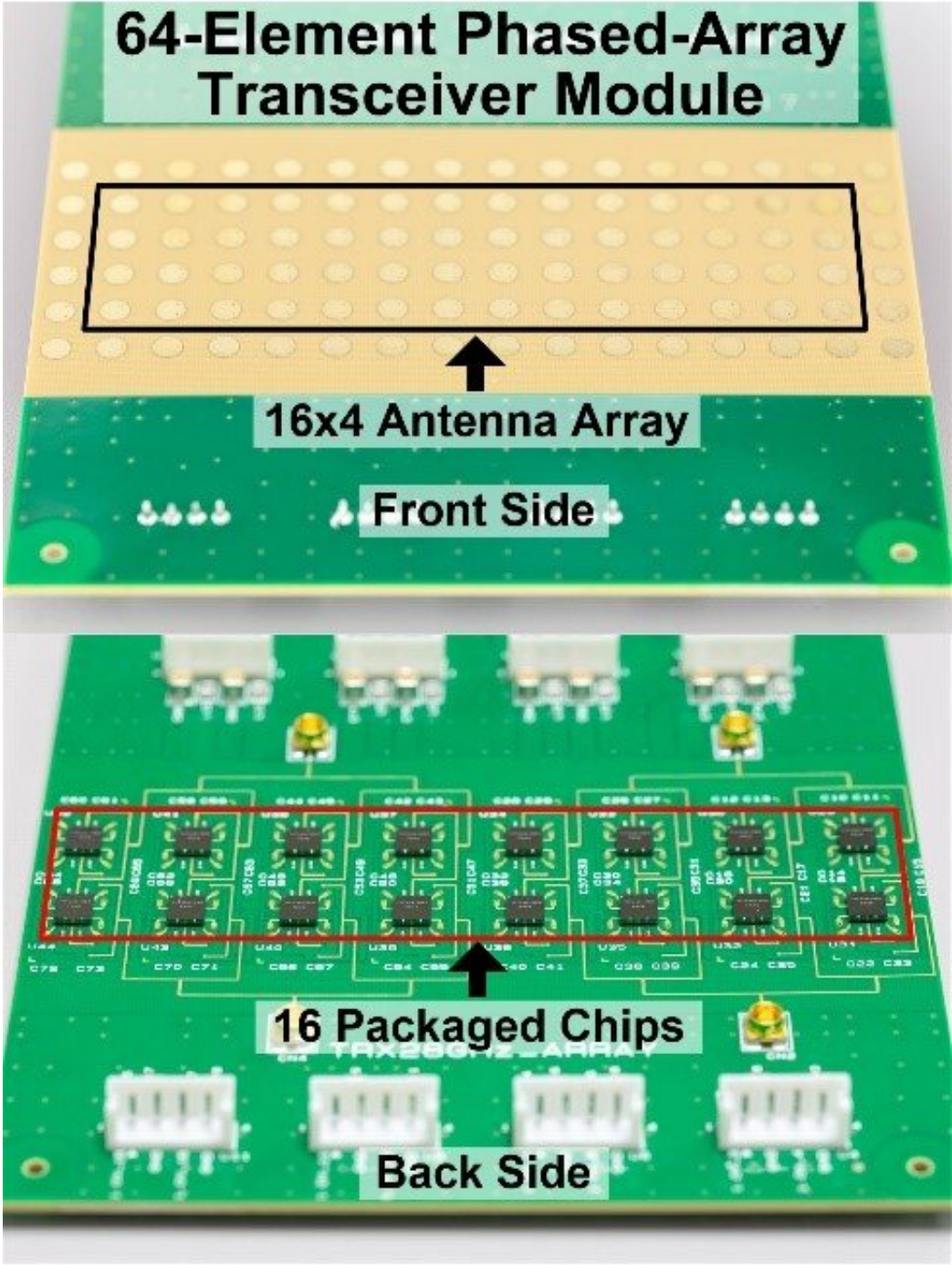

Researchers at Tokyo Institute of Technology and NEC Corporation have jointly developed a 28 GHz phased-array transceiver supporting dual-polarized MIMO for fifth-generation mobile communications system (5G) radio units. Advances in 5G will benefit an array of industries ranging from healthcare, manufacturing and transportation to education and entertainment that require high bandwidth

and high-quality connectivity. Credit: Phased-array radio for polarization MIMO

The transceiver was fabricated using low-cost, mass-producible silicon CMOS[6] technology, occupying an area of just 16 mm². The researchers anticipate that the new circuitry could be installed in a wide range of applications that will be enabled by 5G in the future. Importantly, they point out that their [transceiver](#) will improve spectrum efficiency while keeping equipment size and set-up costs to a minimum.

The findings are being presented at the 2020 Symposia on VLSI Technology and Circuits (VLSI 2020), held online from 14 June. The paper has also been selected as one of the technical highlights at the conference.

More information: Pang et al. A 28-GHz CMOS Phased-Array Beamformer Supporting Dual-Polarized MIMO with Cross-Polarization Leakage Cancellation, 2020 Symposia on VLSI Technology and Circuits vlsisymposium.org/

Provided by Tokyo Institute of Technology

Citation: Researchers develop a compact 28 GHz transceiver supporting dual-polarized MIMO (2020, June 17) retrieved 26 September 2023 from <https://techxplore.com/news/2020-06-compact-ghz-transceiver-dual-polarized-mimo.html>

<p>This document is subject to copyright. Apart from any fair dealing for the purpose of private study or research, no part may be reproduced without the written permission. The content is provided for information purposes only.</p>
--