

A reconfigurable ferroelectric field-effect transistor for frequency multiplication

June 12 2020, by Ingrid Fadelli

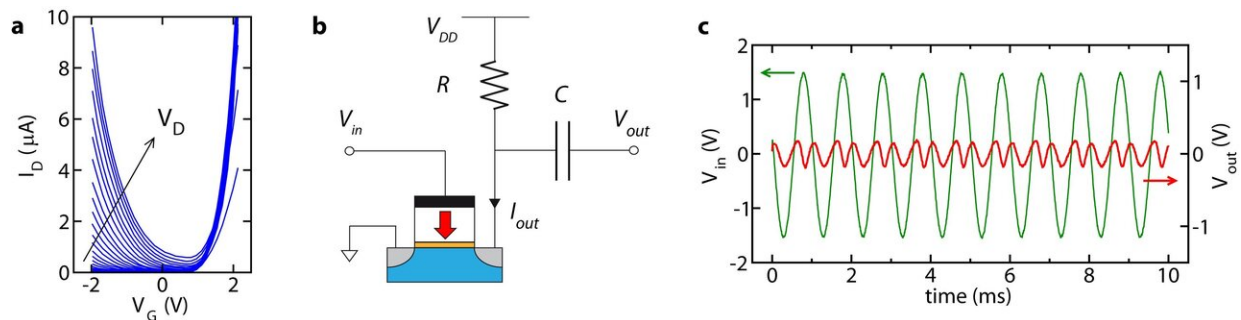

Figure explaining the working principle behind the recent study (1a and 1b) and showing the experimental results collected by the researchers(1c). Credit: Mulaosmanovic et al.

Frequency multipliers, circuits that can produce signals with multiple frequencies, are essential components for a number of technological tools, particularly wireless communications systems. Most existing multipliers, however, are built using filtering and amplification circuits that are bulky and rapidly drain a lot of power.

Researchers at NaMLab in Germany have recently devised a single ferroelectric field-effect transistor that can serve both as a full-wave rectifier and frequency multiplier. The device they developed, presented in a paper published in *Nature Electronics*, is fully reconfigurable and energy-efficient, as it can be used in isolation, not requiring any

additional circuits.

"Our institute (NaMLab) has been doing research on ferroelectric hafnium oxide (HfO_2) since this material's ferroelectric properties were discovered in 2007," Halid Mulaosmanovic, one of the researchers who carried out the study, told TechXplore. "An attractive electronic device that can be made using this material is a ferroelectric field-effect transistor (FeFET), which resembles conventional logic transistors, but has a ferroelectric layer in the gate stack."

HfO_2 can reversibly and rapidly switch between two stable crystalline configurations. This unique property enables the development of FeFETs that can be used both as non-volatile memories and neuromorphic devices. The researchers at NaMLab have been investigating both of these applications of HfO_2 -based FeFETs in collaboration with GLOBALFOUNDRIES, a Dresden-based company that fabricates high quality FeFETs.

As part of their research, Mulaosmanovic and his colleagues studied the responses of FeFETs with different ferroelectric configurations in their gate stack. Interestingly, they noticed that when following a specific set of fabrication and electrical parameters, these transistors' current-voltage (I-V) characteristics became increasingly symmetric, taking on a parabolic shape.

This symmetry was enhanced further by a specific kind of leakage current dubbed gate-induced drain leakage (GIDL). Interestingly, GIDL currents can also be found in classical transistors, but in this case, they are undesirable and can hinder the transistors' performance.

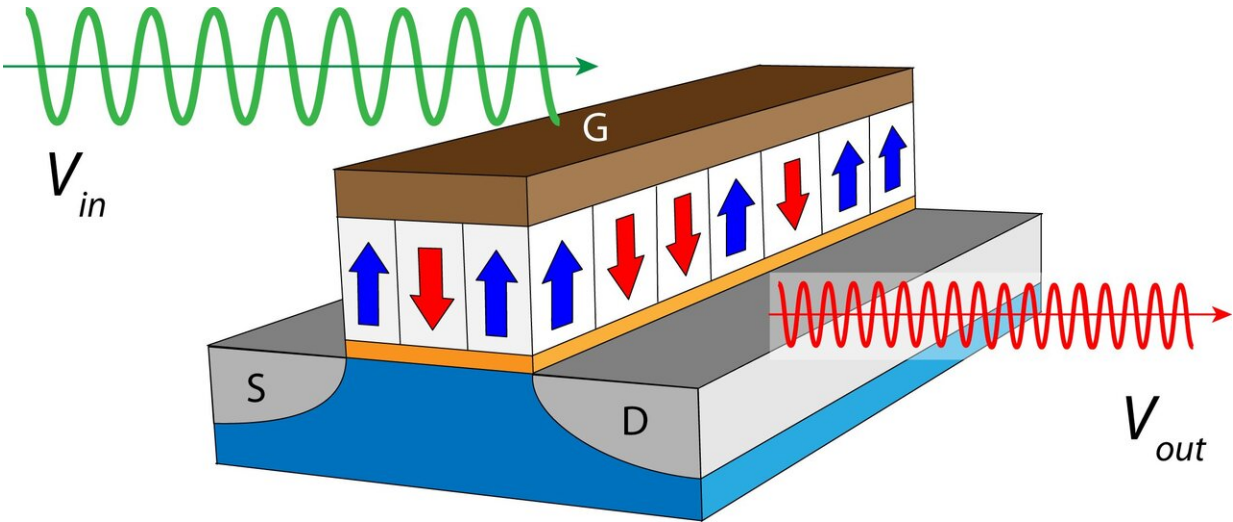

Figure showing how one signal (green sinusoid) arrives to the FeFET device and a second one (red sinusoid) with a doubled frequency is achieved at the output. While this figure is without scientific rigour, it is a simple sketch that exemplifies the idea behind the paper. Credit: Mulaosmanovic et al.

"Notably, we found that a high degree of the I-V symmetry was only enabled by the ferroelectric properties of the device, which is probably the reason why this behavior has not been observed in conventional (non-ferroelectric) transistors so far," Mulaosmanovic said. "This striking symmetry triggered the idea of frequency multiplication, because such parabolic I-V curves naturally promote the phenomenon of frequency doubling."

The study carried out by Mulaosmanovic and his colleagues draws inspiration from previous studies investigating frequency multiplication. For instance, in the 1980s researchers predicted that symmetry in the I-V curves of resonant tunneling diodes could have several benefits for frequency multiplication; a prediction that later proved to be true. In the past, some research teams also designed graphene FETs with symmetric

ambipolar I-V curves for similar purposes.

"By carefully tuning the amount of the switched ferroelectric domains in the FeFET and simultaneously enabling a sufficient level of the GIDL current under a proper device biasing, highly symmetric I-V characteristics can be obtained, which closely resemble those of a parabola," Mulaosmanovic explained. "Subsequently, when a sinusoidal signal with a certain input frequency is applied to such a device, the output current will have double the input frequency. This happens because the parabola gives always a positive output both for a negative and positive input signal swing."

In their recent paper, Mulaosmanovic and his colleagues presented a single device with frequency doubling properties that works without additional filtering circuits, which are instead required by conventional multipliers. Due to the lack of these circuits, the device is more compact than existing multipliers and it uses up less power, which makes it ideal for numerous practical applications.

The new FeFET relies on a field effect to complete write and read operations, which makes it very fast and leads to lower power consumption. In addition, the HfO₂-based transistor is electrically reconfigurable, which means that it can act both as a frequency doubler and transmitter.

"The design strategy we devised is completely reconfigurable, in the sense that you can either activate the multiplication property or turn it off just by electrically reprogramming the FeFET, i.e. by switching its ferroelectric to the other crystalline state," Mulaosmanovic said. "This reconfigurability provides an add-on value and a great design flexibility."

The HfO₂-based FeFET created by the researchers is highly scalable and the researchers showed that it can be scaled down to 20nm of the

channel length. It is also CMOS compatible, thus it can be easily fabricated employing existing industrial processes.

"Our FeFETs can be co-integrated with classical logic transistors, which will be extremely useful to build FeFET-based radiofrequency circuits on a single chip," Mulaosmanovic said. "Our work also offers an example of how a harmful device property, such as the GIDL, can be turned into an advantage. In fact, device engineers and circuit designers typically tend to avoid the GIDL, but we were able to exploit it in a very useful manner."

In the future, the device developed by Mulaosmanovic and his colleagues could be used as a substitute for more conventional frequency multipliers, enhancing the power-efficiency of wireless communication systems and radiofrequency circuits. So far, the researchers were only able to use their FeFET to double frequencies within a 1MHz range, due to limitations associated with their experimental setup and non-optimal device integration. In their next studies, however, they will explore ways in which this range of frequencies could be expanded.

"We now plan to further investigate different integration possibilities: e.g. different semiconductor channel materials could largely boost the frequency range (e.g., strained Silicon or Germanium) as well as more advanced integration schemes, such as FinFET or silicon-on-insulator (SOI) technology could be a better choice," Mulaosmanovic said. "We also plan to improve the spectral purity of the output signal and one approach could be to further tune the ferroelectric properties of the device. There is still plenty of room for improvement, but FeFET is a very promising [device](#) and we expect lot more advances for this exciting application."

More information: Halid Mulaosmanovic et al. Reconfigurable frequency multiplication with a ferroelectric transistor, *Nature*

Electronics (2020). [DOI: 10.1038/s41928-020-0413-0](https://doi.org/10.1038/s41928-020-0413-0)

© 2020 Science X Network

Citation: A reconfigurable ferroelectric field-effect transistor for frequency multiplication (2020, June 12) retrieved 4 August 2024 from <https://techxplore.com/news/2020-06-reconfigurable-ferroelectric-field-effect-transistor-frequency.html>

This document is subject to copyright. Apart from any fair dealing for the purpose of private study or research, no part may be reproduced without the written permission. The content is provided for information purposes only.